



### DESCRIPTION

**High-quality, American-made shower elements add consistency, style, and functionality to any custom tile or stone shower installation**

- ◇ Waterproof Coating is Meets ANSI 118.10 Requirements
- ◇ Quick & Easy to Install - Save Time & Money
- ◇ Strong and Lightweight
- ◇ Constructed of High-Density Polystyrene
- ◇ Interior & Exterior Applications
- ◇ Can also be Used in Kitchens, Hallways, and Other Living Areas
- ◇ Several Sizes and Designs to Choose From
- ◇ Made in the USA

### AVAILABLE STYLES/SIZES

12"x12" Square Niche  
SKU: **CN-S12**

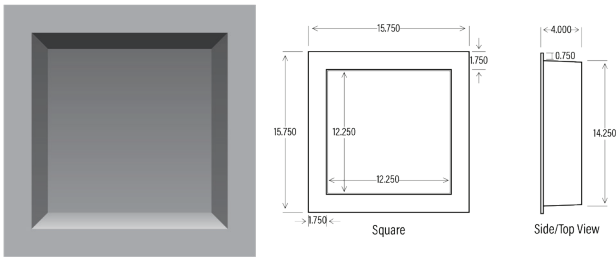

12"x20" Rectangle Niche  
SKU: **CN-R1220**

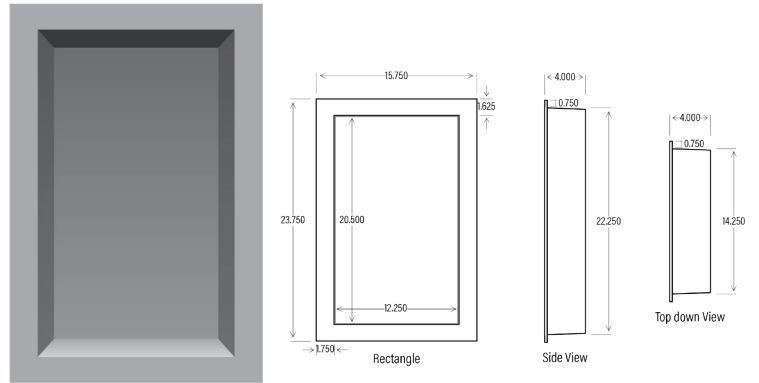

12"x20" Double Niche  
SKU: **CN-D1220**

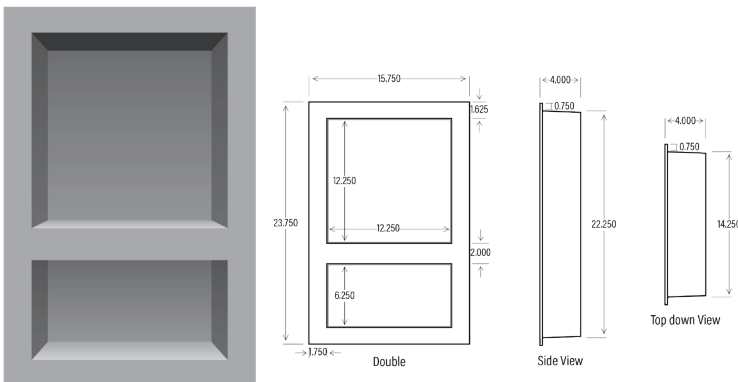

12"x20" Arched Double Niche  
SKU: **CN-AD1220**

